

APPLICATION SPECIFIC INDUCTOR

General Description

NLDM3532-X is a specific designed inductor for discrete LAN transformer, which work with NLCM0805-X common mode choke to construct a patented discrete LAN solution.

Features

- ◆ 10/100 & Gigabit Ethernet application
- ◆ Surge capability (50A @ 5/310us)
- ◆ Surface Mount Device
- ◆ Lead Free & Halogen Free

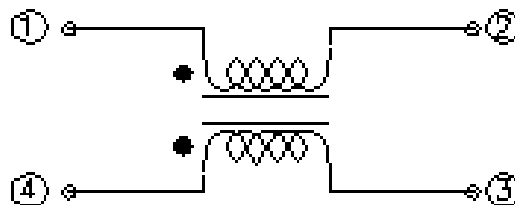
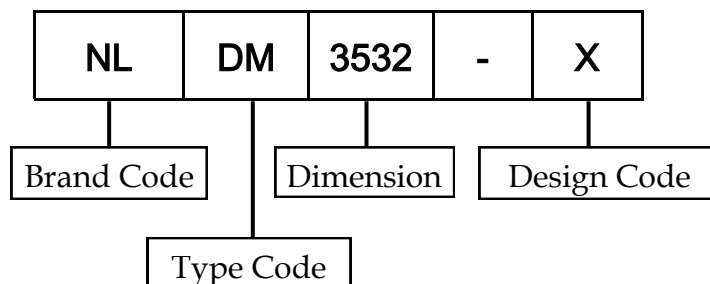

Fig.1 Pin Configuration

Ordering Information



DEVICE CHARACTERISTICS

Electrical Characteristics			
Parameter	Symbol	Value	Units
Inductance (100KHz)	L_D	320	μH
Surge Rating (5/310us)	I_{PP}	50	A
Rated Voltage	V_R	50	V
Maximum Operation DC Current	I_{DC}	200	mA
DC Resistance	R_{DC}	1.4	Ω
Operation Temperature	T_J	-40~85	$^{\circ}C$
Storage Temperature	T_S	-40~85	$^{\circ}C$

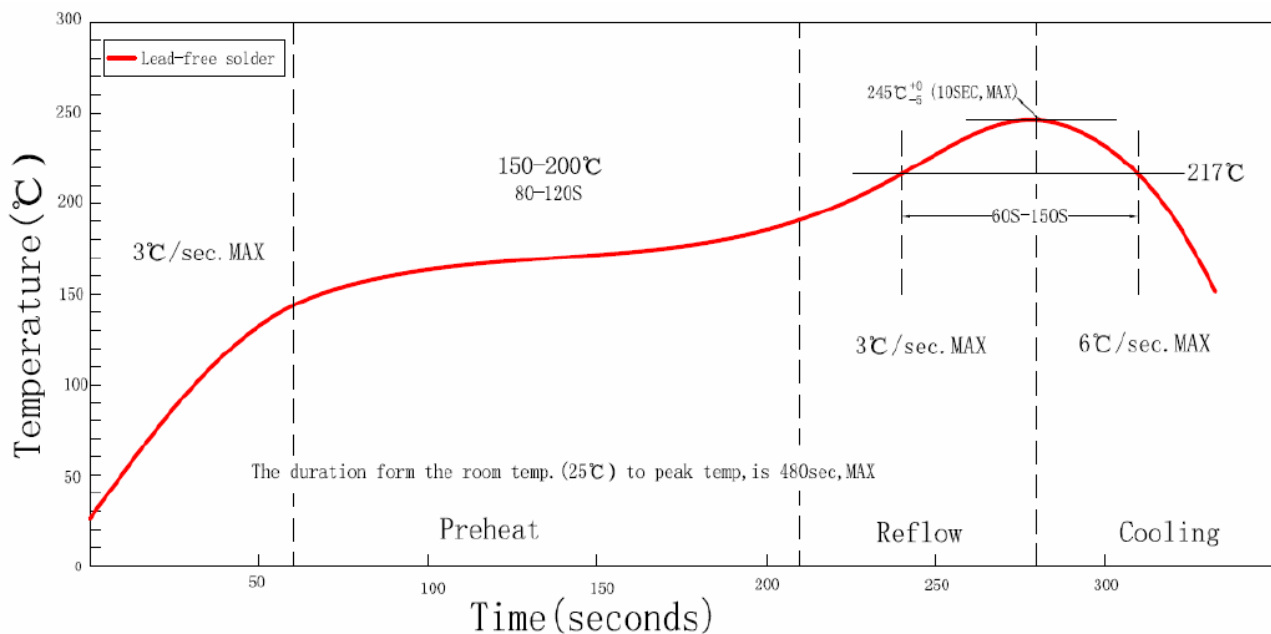

Fig.2 General Reflow Profile

MECHANICAL CHARACTERISTICS

Material & Finish	
Position	Material
Upper Plate	Ferrite
Contact	Copper Alloy
Contact Plating	Tin
Wire	Copper Wire
Core	Ferrite Core

TYPICAL APPLICATION

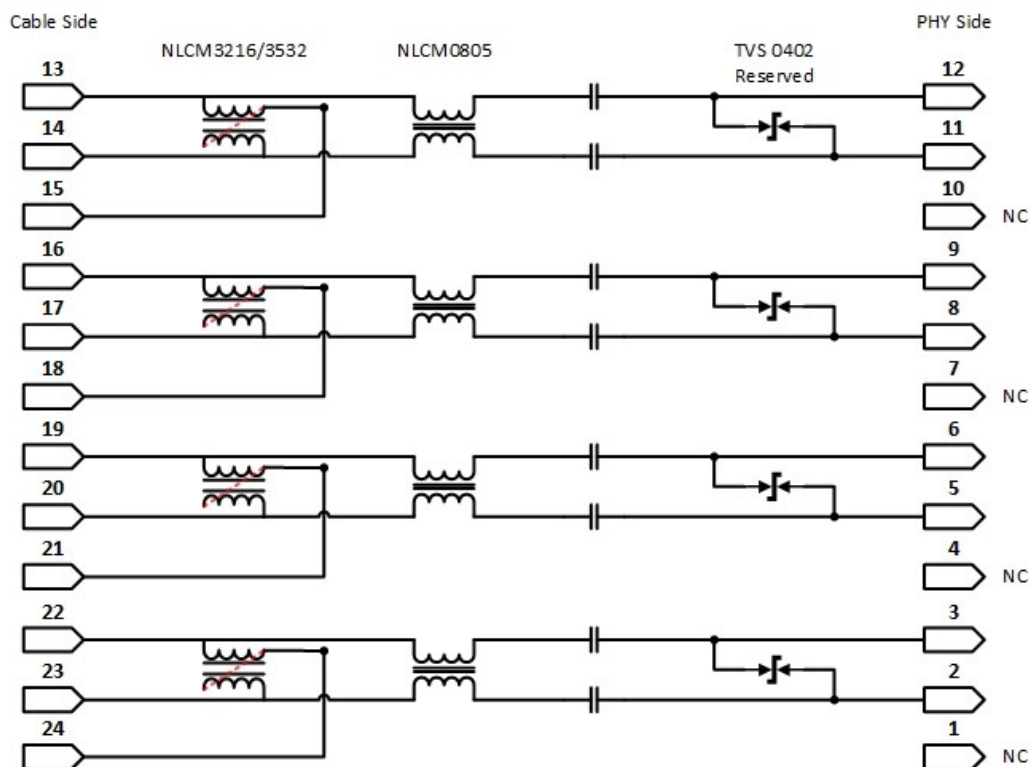
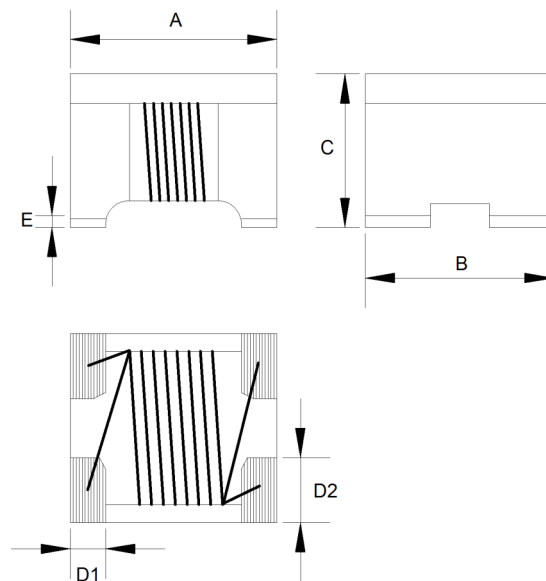

Fig.3 Typical Application

DEVICE OUTLINE

Outline Dimension				
Symbol	Millimeters		Inches	
	Min	Max	Min	Max
A	3.30	3.70	0.130	0.145
B	3.00	3.40	0.118	0.134
C	2.40	2.80	0.094	0.110
D1	0.55	0.65	0.021	0.026
D2	1.07	1.17	0.042	0.046
E	0.15TYP		0.006TYP	



Revision History	Modification Description
Rev.1.0	Initial Release