

APPLICATION SPECIFIC INDUCTOR

General Description

NLCM0805-X is a specific designed Common Mode Choke for discrete LAN transformer, which work with NLDM3216-X or NLDM3532-X inductor to construct a patented discrete LAN solution.

Features

- ◆ 10/100 & Gigabit Ethernet application
- ◆ High Common Mode Impedance
- ◆ Surface Mount Device
- ◆ Lead Free & Halogen Free

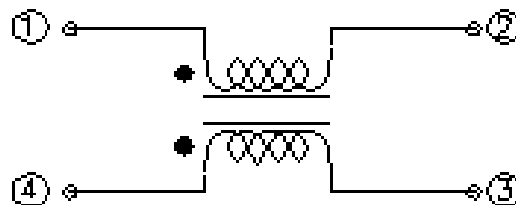
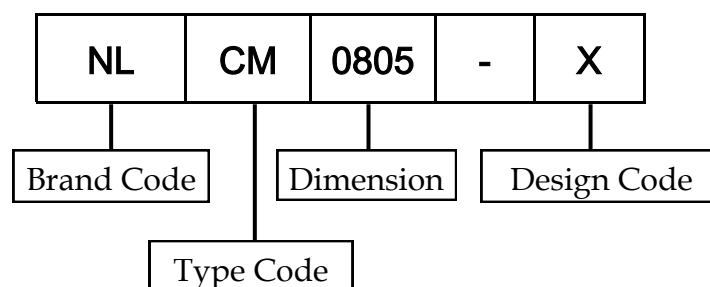

Fig.1 Pin Configuration

Ordering Information



DEVICE CHARACTERISTICS

Electrical Characteristics			
Parameter	Symbol	Value	Units
Common Mode Impedance (100MHz)	Z_C	800	Ω
Rated Voltage	V_R	125	V
Maximum Operation DC Current	I_{DC}	100	mA
DC Resistance	R_{DC}	1	Ω
Operation Temperature	T_J	-40~85	$^{\circ}C$
Storage Temperature	T_S	-40~85	$^{\circ}C$

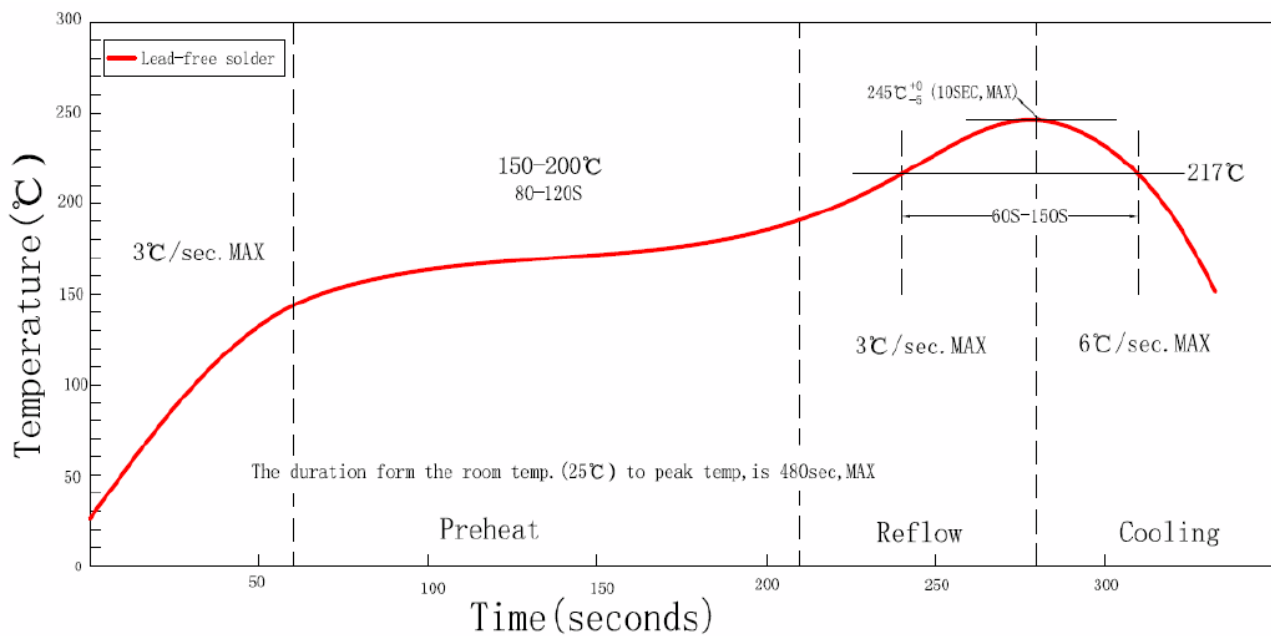

Fig.2 General Reflow Profile

MECHANICAL CHARACTERISTICS

Material & Finish	
Position	Material
Upper Plate	Ferrite
Contact	Copper Alloy
Contact Plating	Tin
Wire	Copper Wire
Core	Ferrite Core

TYPICAL APPLICATION

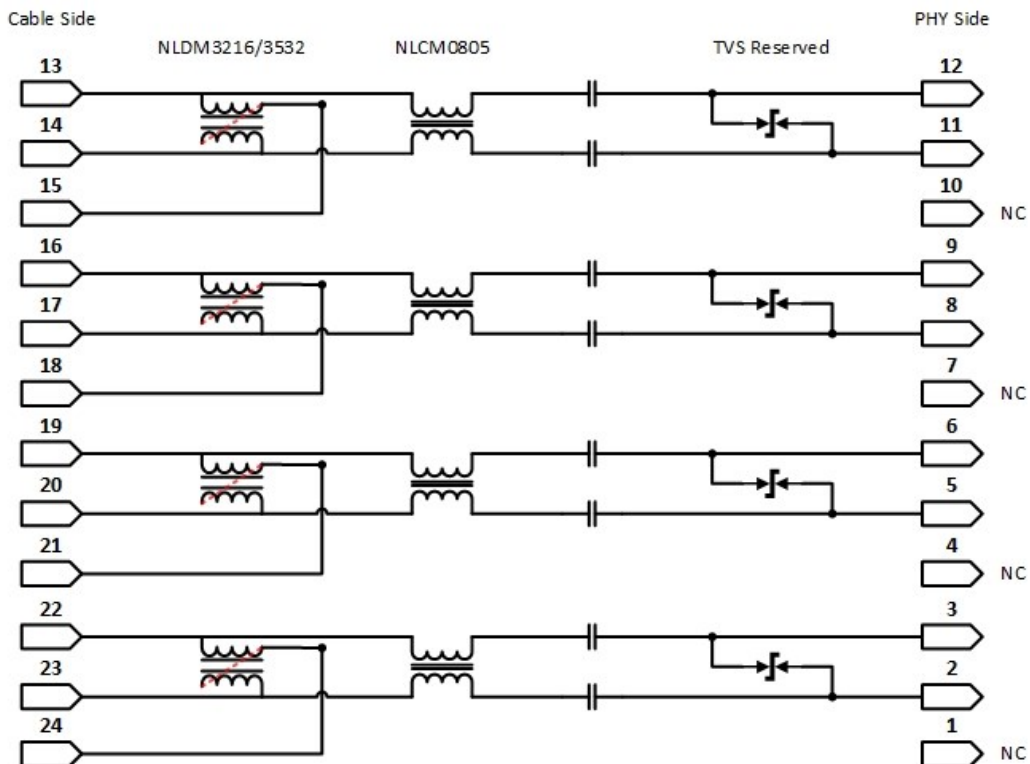
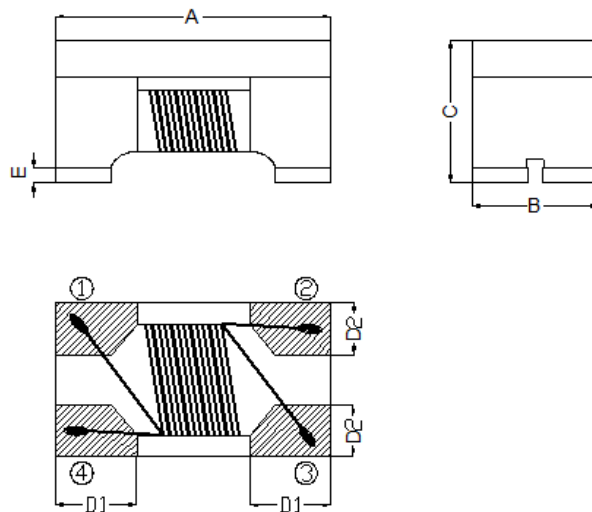

Fig.3 Typical Application

DEVICE OUTLINE

Outline Dimension				
Symbol	Millimeters		Inches	
	Min	Max	Min	Max
A	1.80	2.20	0.07	0.087
B	1.00	1.40	0.039	0.055
C	1.00	1.40	0.039	0.055
D1	0.45	0.65	0.017	0.026
D2	0.36	0.56	0.014	0.022
E	0.15TYP		0.006TYP	



Revision History	Modification Description
Rev.1.0	Initial Release